

Anna

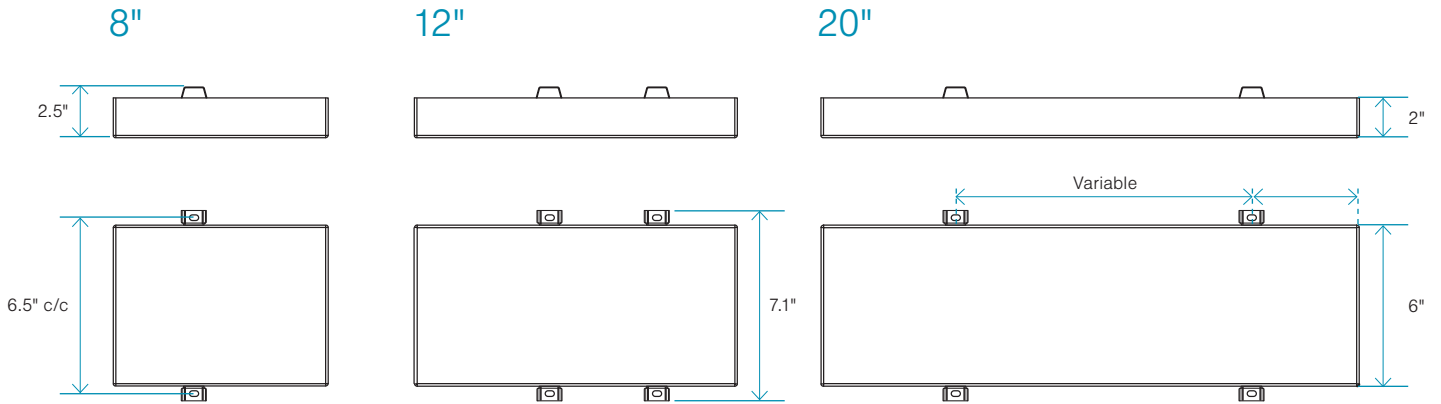

FASTENED STONE ACCENT SYSTEM



NOMINAL WIDTH	HEIGHT	DEPTH	FASTENING SYSTEM	OVERALL DIMENSIONS
8"	6"	2"	Screw-in	8" x 7.1" x 2.5"
12"	6"	2"	Screw-in	12" x 7.1" x 2.5"
20"	6"	2"	Screw-in	20" x 7.1" x 2.5"

General Specifications

SUBSTRATE

- Cement and 35% recycled post-consumer glass composite.

PACKAGING

- 28.33 sq. ft. crates of stones.

WEIGHT OF A CRATE

- 400 lbs.

AVAILABLE COLORS

- Charcoal;
- Stonehenge.

Colors juxtaposed on a textured cement base to achieve that sought-after natural stone look. Rich variations that give each project its own unique personality.

WARRANTY

- 25 years

TECHNICAL SPECS

- Each crate contains:
 - Ratio of 2 x 20" stones to 1 x 8" stone and 1 x 12" stone;
 - 32 different surface patterns to ensure variability in final result;
 - Approximately 18 identified corner stones.

For exterior and interior use.